

MNPE-09425068494

KARNATAKA STATE OPEN UNIVERSITY

DIPLOMA IN ELECTRICAL AND ELECTRONICS

ENGINEERING

SEMESTER SYSTEM

SYLLABUS

**I YEAR SYLLBUS Basic Engineering
(Common to all Branches)**

Subject Code	Subject Title	Max Marks	Max Credits
Semester-I			
BE101	Communication English	100	4
BE102	Applied Mathematics-1	100	4
BE103	Engineering Physics-I	100	4
BE104	Engineering Chemistry-I	100	4
BE105	Computer Application Lab	100	2
BE106	Workshop Practice Lab	100	2
Semester -II			
BE201	Applied Mathematics-II	100	4
BE202	Engineering Physics-II	100	4
BE203	Engineering Chemistry-II	100	4
BE204	Engineering Graphics	100	4
BE205	Physics Lab	100	2
BE206	Chemistry Lab	100	2

**Electrical and Electronics Engineering
III Semester**

Subject Code	Subject Title	Max Marks	Max Credits
EE301	Circuit Theory	100	4
EE302	Electronic Devices	100	4
EE303	Electrical Machines-I	100	4
EE304	Engineering Mechanics	100	4
EE305	Electronic Devices Lab	100	2
EE306	Electrical Machines –I	100	2

**Electrical and Electronics Engineering
IV Semester**

Subject Code	Subject Title	Max Marks	Max Credits
EE401	Linear and Digital ICs	100	4
EE402	Computer Hardware and Networking	100	4
EE403	Electrical Machines-II	100	4
EE404	Measurements and Instruments	100	4
EE405	IC Lab	100	2

EE406	Electrical Machines –I I Lab	100	2
-------	------------------------------	-----	---

**Electrical and Electronics Engineering
V Semester**

Subject Code	Subject Title	Max Marks	Max Credits
EE501	Power Systems I	100	4
EE502	Microprocessor and Microcontrollers	100	4
EE503	Electrical Machine Design	100	4
EE504	Control of Electrical Machines	100	4
EE505	Control of Electrical Machines Lab	100	2
EE506	Microcontrollers Lab	100	2

**Electrical and Electronics Engineering
VI Semester**

Subject Code	Subject Title	Max Marks	Max Credits
EE601	Power Systems II	100	4
EE602	Power Electronics	100	4
EE603	Electrical Estimation	100	4
EE604	Power Electronics Lab	100	2
EE605	Project	400	8

Total Marks = 3800

Total Credits = 122

SEMESTER : I
Subject Code : BE 101
Subject Title : Communication English

Structure of the Course Content

BLOCK 1 Grammar (Non-Textual)

- Unit 1: Functional Analysis
- Unit 2: Voice and parts of speech
- Unit 3: Direct and indirect speech
- Unit 4: Preposition

BLOCK 2 Grammars

- Unit 1: One word substitute
- Unit 2: Articles and question tags
- Unit 3: Prefixes and suffixes
- Unit 4: Tenses

BLOCK 3 Compositions

- Unit 1: Comprehension
- Unit 2: Simple passage
- Unit 3: Moral story
- Unit 4: Science and technology

BLOCK 4 Letter and dialogue Writing

- Unit 1: Letter writing - personal
- Unit 2: Letter writing - official
- Unit 3: Dialogue writing
- Unit 4: Hints development

BLOCK 5 Proses

- Unit 1: An Astrloger's day – R.K. Narayanan
- Unit 2: The sun, the planets and the stars – C.Jones
- Unit 3: The continuing spell of Ramanujam
- Unit 4: On saying 'please' – A.G.Gardiner

Books:

1. Orient Longman, Anna Salai, Chennai-600002.
2. The Advanced Learners Dictionary of Current English by A.S.Hornby, Oxford University Press. 1973
3. High School English Grammar and Composition by Wren & Martin, S.Chand & Co
4. Vocabulary in Practice - Part 1 to 4 by Glennis Pye, Cambridge University Press,
5. Learn Correct English by Shiv K. Kumar & Hemalatha Nagarajan, Pearson Longman, 2005
6. Essential English Grammar by Raymond Murphy, Cambridge University Press,
7. Common Errors in English by M.Thomas, Lotus Press, New Delhi, 2006
8. Basic English Usage by Michael Swan, ELBS/OUP, 1989

9. Communication Skills for Engineers by Mishra ,Ist Edition, Pearson Longman
10. Basic English Dictionary by Longman Longman Ist Edition, Pearson Longman

SEMESTER : I
Subject Code : BE 102
Subject Title : Applied Mathematics - I

Structure of the Course Content

BLOCK 1 Algebra

- Unit 1: Determinants
- Unit 2: Matrices
- Unit 3: Permutation and combination
- Unit 4: Binomial Theorem

BLOCK 2 Complex numbers

- Unit 1: Real and imaginary parts
- Unit 2: Demoivre's Theorem
- Unit 3: Finding the n^{th} roots of unity
- Unit 4: Solving equations

BLOCK 3 Analytical geometry

- Unit 1: Pair of straight lines
- Unit 2: Circles
- Unit 3: Family of circles
- Unit 4: Concentric circles

BLOCK 4 Trigonometry

- Unit 1: Compound angles
- Unit 2: Multiple angles
- Unit 3: Sub multiple angles
- Unit 4: Sum and product formulae

BLOCK 5 Differential calculus

- Unit 1: Limits
- Unit 2: Differentiation
- Unit 3: Differentiation methods
- Unit 4: Successive differentiation

Books :

1. Engineering Mathematics by Dr M.K.Venkatraman, National Publishing Co.
2. Engineering Mathematics by Dr P.Kandasamy, S.Chand & Co, New Delhi
3. Higher Engineering Mathematics by Ramana, Tata McGraw Hill, New Delhi
4. Engineering Mathematics by Singh, Tata McGraw Hill, New Delhi
5. Advanced Engineering Mathematics by N.Bali,M.Goyal,C.Watkins,Lakshmi Publications (Pvt) Ltd, New Delhi
6. Engineering Maths by T.Veerarajan, Tata McGraw Hill, New Delhi
7. Schaum's Outline of Technical Mathematics by Paul Calter, Tata McGraw Hill, New Delhi
8. Engineering Mathematics Vol-III by Dr. B. Krishna Gandhi , Dr. T.K.V Iyengar,

S.Ranganatham, , S.Chand & Co, New Delhi

9. Introduction to Engineering Mathematics by H.K. Dass, Dr.Rama Verma, S.Chand & Co, New Delhi

10. Applied Engineering Mathematics Vol-II by H.K.Dass, S.Chand & Co

SEMESTER : I
Subject Code : BE 103
Subject Title : Engineering Physics - I

Structure of the Course Content

BLOCK 1 S I units and Statics

Unit 1: Fundamental quantities

Unit 2: Derived quantities

Unit 3: Concurrent forces

Unit 4: parallelogram Law of forces

BLOCK 2 Properties of matter

Unit 1: Stress and strain

Unit 2: Young's modulus

Unit 3: Viscosity

Unit 4: Surface Tension

BLOCK 3 Dynamics

Unit 1: Projectile Motion

Unit 2: Angle of projection

Unit 3: Circular Motion

Unit 4: Application of circular motion

BLOCK 4 Rotational motions of rigidity bodies

Unit 1: Moment of Inertia

Unit 2: Kinetic energy

Unit 3: Angular Momentum

Unit 4: Kepler's Law

BLOCK 5 Remote sensing and sound

Unit 1: Active and Passive remote sensing

Unit 2: Microwave remote sensing

Unit 3: Types of sound waves

Unit 4: Acoustics

Books :

1. Physics by Resnick and Hoilday ,Wisley Toppan Publishers – England
2. Mechanics by Narayana Kurup , S. Chand Publishers – New Delhi
3. Engineering Physics by B.L. Theraja , S. Chand Publishers – New Delhi
4. Remote sensing by Dr.M.Anji Reddy, Jawaharlal Nehru Technological University – Hyderabad.
5. Engineering Physics by V.Rajendran, Tata McGraw Hill, New Delhi
6. Engineering Physics by Vikram Yadav, Tata McGraw Hill, New Delhi
7. Schaum's Outline of Physics for Engineering and Science by Michael Browne, Tata McGraw Hill, New Delhi
8. Modern Engineering Physics by A.S.Vasudeva, S. Chand Publishers, New Delhi

- 9.Engineering Physics Fundamentals & Modern Applications by P.Khare and A.Swarup, Lakshmi Publications (Pvt) Ltd, New Delhi
10. Engineering Physics by Dipak Chandra Ghosh,Nipesh Chandra Ghosh,Prabir Kumar Halder, Lakshmi Publications (Pvt) Ltd, New Delhi

SEMESTER : I
Subject Code : BE 104
Subject Title : Applied Chemistry - I

Structure of the Course Content

BLOCK 1 Acids – Bases, Catalysis

- Unit 1: Theories of Acids and Bases
- Unit 2: Industrial application
- Unit 3: Positive and Negative catalyst
- Unit 4: Characteristics of Catalyst

BLOCK 2 Pollution

- Unit 1: Air Pollution
- Unit 2: Global warming
- Unit 3: Water Pollution
- Unit 4: Green Chemistry

BLOCK 3 Electro chemistry and corrosion

- Unit 1: Types of conductors
- Unit 2: Industrial applications of Electrochemistry
- Unit 3: Electrochemical theory
- Unit 4: Electroplating

BLOCK 4 Organic coatings

- Unit 1: Paint
- Unit 2: Varnish
- Unit 3: Adhesives
- Unit 4: Lubricants

BLOCK 5 Colloids and Ceramics

- Unit 1: Colloidal solution
- Unit 2: Brownian movement
- Unit 3: Water purification
- Unit 4: Ceramics

Books :

1. Inorganic chemistry by Soni PL, Sultan Chand &sons.
2. Organic chemistry by Soni PL, Sultan Chand & sons.
3. Engineering chemistry by Jain & Jain, Dhanpat rai &co
4. Engineering chemistry by Uppal , Khanna publishers
5. Environmental chemistry &Pollution control by Dara .SS, S. Chand&co
6. Environmental Pollution by . Tripathy .SN , Sunakar panda - Vrinda publication
7. Rain water Harvesting-hand book by Chennai Metro Water
8. Introduction to Engineering Chemistry by Minaxi B Lohani, Upma Misra, S.Chand & Co, New Delhi
9. Engineering Chemistry by Dr.A.K.Pahari,Dr.B.S.Chauhan, Lakshmi Publications

(Pvt) Ltd, New Delhi
10. Advanced Engineering Chemistry by M.Senapati, Lakshmi Publications (Pvt) Ltd,
New Delhi

SEMESTER : **I**
Subject Code : **BE 105**
Subject Title : **Computer Application Lab**

Practicals **Windows**

- 1.a. Starting a program, running a program.
 - b. Starting the Windows in safe mode
 - c. Running multiple Programs and switching between windows.
 - d. Moving the windows, and the task bar.
 - e. Startup to MS-DOS prompts.
- 2.a. Creating and removing a folder.
 - b. Making the taskbar wider, arranging icons on the Desktop.
 - c. Displaying and hiding the taskbar clock.
 - d. Controlling the size of start menu options.
 - e. Creating shortcuts.
- 3.a. Installing a screen saver.
 - b. Assigning Wallpaper to Desktop.
 - c. Adding a program to the start menu.
 - d. Recovering files and folders from Recycle bin.
 - e. Customizing the mouse settings.
- 4 a. Expanding and collapsing a folder.
 - b. Recognizing file types using icons.
 - c. Running a program from explorer.
 - d. Renaming a file or folder.
 - e. Selecting two or more files for an operation.
- 5.a. Displaying the properties for a file or folder.
 - b. Using cut and paste operations to copy a file.
 - c. Using copy and paste operations to copy a file.

- d. Moving and copying files with mouse.
- e. Sorting a folder.
- 6.a. Finding a file or folder, by name.
- b. Defragmenting the disk using disk defragmenter.
- c. Compressing a file using WinZip.
- d. Controlling the speaker volume.
- e. Recording and saving an audio file.

MS Word

- a. Prepare a newsletter with borders, two columns text, header and footer and a graphic image and spell check the document.
- b. Create a table to show the paradigm of the verb “eat” in all 12 tenses

Tense		Present	Past	Future
Simple	He	Eats	Ate	Will eat
	I	Eat	Ate	Will eat
	You/They	Eat	Ate	Will eat
Continuous	He	Is eating	Was eating	Will be eating
	I	Am eating	Was eating	Will be eating
	You/They	Are eating	Was eating	Will be eating
Perfect	He	Has eaten	Had eaten	Will have eaten
	I	Have eaten	Had eaten	Will have eaten
	You/They	Have eaten	Had eaten	Will have eaten
Perfect continuous	He	Has been eating	Had been eating	Will have been eating
	I	Have been eating	Had been eating	Will have been eating
	You/They	Have been eating	Had been eating	Will have been eating

- c. Prepare your Bio-data/Resume
- d. Do the mail merge operation for sending applications to many companies with your resume

MS EXCEL

- 1. Create a worksheet in Excel for a company:
 - a. Copy, Move and Merge the cells
 - b. Adding Comments
 - c. Adding, Deleting the cells, Rows and Columns

d. Hiding and Unhiding the columns, Rows and gridlines.

2. Using formula and functions prepare worksheet for storing subject marks of ten students and perform the following:

- a. Calculate the student wise total and average
- b. Calculate the subject wise total and average
- c. Calculate the overall percentage and also individual percentage of the student.

3. Create Bar Graph and Pie Chart for various data

MS Power Point

- a. Create a simple presentation with atleast 5 slides to introduce your friend and include sounds in slides.
- b. Create a presentation with 5 slides for the essay Astrologer's Day by R.K Narayanan

Internet

- a. Creating an E-Mail account.
- b. Sending an E-Mail to a known Address
- c. Viewing an E-Mail received from your friend/relative.
- d. Printing an E-Mail received
- e. Use of Attachment Facility
- f. Use of Address Book Facility
- g. Use of Sent Folder
- h. Use of Save Draft Folder
- i. Use of Trash Folder
- j. Browse a given web-site address.
- k. Search a Particular topic through a Search engine.

SEMESTER : I
Subject Code : BE 106
Subject Title : Workshop Practice

Fitting

1. Fitting
2. V - Joint
3. L - Joint
4. T - Joint
5. Half round joint
6. Dovetail Joint
7. U – Joint
8. Hexagonal – Joint
9. Step - Joint
10. Drilling and Tapping M8
11. Drilling and Tapping M10

Wiring

1. Single lamp controlled by single switch.
2. Two Lamps controlled by Two independent switches.
3. Stair case Wiring
4. Fluorescent lamp circuit.
5. Circuit diagram of a fan
6. Circuit diagram of an iron box
7. Circuit diagram of a mixie
8. Soldering practice

Sheet Metal

1. Hemming
2. Seaming
3. Tray
4. Cylinder
5. Cone
6. Hopper
7. Dust Pan
8. Funnel

SEMESTER : II
Subject Code : BE 201
Subject Title : Applied Mathematics - II

Structure of the Course Content

BLOCK 1 Vector Algebra

- Unit 1: Introduction
- Unit 2: Vector Properties
- Unit 3: Product of Vectors
- Unit 4: Application of Vectors

BLOCK 2 Integral Calculus

- Unit 1: Integration
- Unit 2: Standard Integrals
- Unit 3: Integration by parts
- Unit 4: Bernoulli's Theorem and Applications

BLOCK 3 Differentiation

- Unit 1: Velocity and Acceleration
- Unit 2: Tangents and Normals
- Unit 3: Maxima and Minima
- Unit 4: Partial differentiation

BLOCK 4 Application of Integration

- Unit 1: Definite Integral.
- Unit 2: Area and Volume
- Unit 3: Solution of differential equations
- Unit 4: Second order differential equation with constant coefficients

BLOCK 5 Probability Distributions

- Unit 1: Continuous random variable
- Unit 2: Discrete random variable
- Unit 3: Discrete Distributions (Binomial, Poisson)
- Unit 4: Continuous Distribution

Books :

1. Engineering Mathematics by Dr M.K.Venkatraman, National Publishing Co.
2. Engineering Mathematics by Dr P.Kandasamy, S.Chand & Co, New Delhi
3. Higher Engineering Mathematics by Ramana, Tata McGraw Hill, New Delhi
4. Engineering Mathematics by Singh, Tata McGraw Hill, New Delhi
5. Advanced Engineering Mathematics by N.Bali,M.Goyal,C.Watkins,Lakshmi Publications (Pvt) Ltd, New Delhi
6. Engineering Maths by T.Veerarajan, Tata McGraw Hill, New Delhi
7. Schaum's Outline of Technical Mathematics by Paul Calter, Tata McGraw Hill, New Delhi

8. Engineering Mathematics Vol-III by Dr. B. Krishna Gandhi , Dr. T.K.V Iyengar, S.Ranganatham, , S.Chand & Co, New Delhi
9. Introduction to Engineering Mathematics by H.K. Dass, Dr.Rama Verma, S.Chand & Co, New Delhi
10. Applied Engineering Mathematics Vol-II by H.K.Dass, S.Chand & Co

SEMESTER : II
Subject Code : BE 202
Subject Title : Engineering Physics - II

Structure of the Course Content

BLOCK 1 Heat

Unit 1: Heat - Kinetic Theory of Gases:

Unit 2: Specific Heat

Unit 3: Isothermal Changes

Unit 4: Adiabatic Changes

BLOCK 2 Gases & Non Conversional Energy

Unit 1: Liquefaction of Gases

Unit 2: Joule Thomson Effect & Linde's process

Unit 3: Renewable and Non-renewable sources

Unit 4: Alternate sources of Energy-

BLOCK 3 Light & Magnetism

Unit 1: Optical Instruments

Unit 2: Lasers

Unit 3: Basic definitions of Magnetism

Unit 4: Hysteresis Loop

BLOCK 4 Electricity

Unit 1: Basic laws

Unit 2: Force on a moving charge

Unit 3: Measuring Instruments

Unit 4: Heating Effect of Electric Current

BLOCK 5 Dielectric effect & Electronics

Unit 1: Chemical Effect of Electric Current

Unit 2: Capacitor

Unit 3: Semiconductors , PN Junction & Transistors

Unit 4: Logic Gates

Books :

1. Physics by Resnick and Hoilday , Wisley Toppan Publishers – England
2. Mechanics by Narayana Kurup , S. Chand Publishers – New Delhi
3. Engineering Physics by B.L. Theraja , S. Chand Publishers – New Delhi
4. Remote sensing by Dr.M.Anji Reddy, Jawaharlal Nehru Technological University – Hyderabad.
5. Engineering Physics by V.Rajendran, Tata McGraw Hill, New Delhi
6. Engineering Physics by Vikram Yadav, Tata McGraw Hill, New Delhi
7. Schaum's Outline of Physics for Engineering and Science by Michael Browne, Tata McGraw Hill, New Delhi

8. Modern Engineering Physics by A.S.Vasudeva, S. Chand Publishers, New Delhi
9. Engineering Physics Fundamentals & Modern Applications by P.Khare and A.Swarup, Lakshmi Publications (Pvt) Ltd, New Delhi
10. Engineering Physics by Dipak Chandra Ghosh, Nipesh Chandra Ghosh, Prabir Kumar Haldar, Lakshmi Publications (Pvt) Ltd, New Delhi

SEMESTER : II
Subject Code : BE 203
Subject Title : Applied Chemistry - II

Structure of the Course Content

BLOCK 1 Nuclear Chemistry

- Unit 1: Radio activity and definitions
- Unit 2: Half life period & Nuclear fission & fusion
- Unit 3: Applications of radioactive isotopes
- Unit 4: Abrasives

BLOCK 2 Fuels and Refractory's

- Unit 1: Fuels - classification
- Unit 2: Solid and Liquid Fuels
- Unit 3: Gas Fuels
- Unit 4: Refractory's

BLOCK 3 Water Treatment

- Unit 1: Water Treatment Methods
- Unit 2: EDTA Method
- Unit 3: Water -purification
- Unit 4: Lime and manufacturing process

BLOCK 4 Plastics and Rubber

- Unit 1: Thermoplastics,
- Unit 2: Thermo set plastics
- Unit 3: Natural rubber-
- Unit 4: Synthetic rubber

BLOCK 5 Metallurgy

- Unit 1: Tungsten & Titanium
- Unit 2: Powder metallurgy
- Unit 3: Purpose of alloying
- Unit 4: Non ferrous alloys

Books :

1. Inorganic chemistry by Soni PL, Sultan Chand & sons.
2. Organic chemistry by Soni PL, Sultan Chand & sons.
3. Engineering chemistry by Jain & Jain, Dhanpat rai & co
4. Engineering chemistry by Uppal , Khanna publishers
5. Environmental chemistry & Pollution control by Dara .SS, S. Chand & co
6. Environmental Pollution by . Tripathy .SN , Sunakar panda - Vrinda publication
7. Rain water Harvesting-hand book by Chennai Metro Water
8. Introduction to Engineering Chemistry by Minaxi B Lohani, Upma Misra, S.Chand & Co, New Delhi

9. Engineering Chemistry by Dr.A.K.Pahari,Dr.B.S.Chauhan, Lakshmi Publications (Pvt) Ltd, New Delhi
10. Advanced Engineering Chemistry by M.Senapati, Lakshmi Publications (Pvt) Ltd, New Delhi

SEMESTER : II
Subject Code : BE 204
Subject Title : Engineering Graphics

Structure of the Course Content

BLOCK 1 Drawing Office Practice

- Unit 1: Basics of Engg Drawing
- Unit 2: Dimensioning
- Unit 3: Scales
- Unit 4: Geometrical Constructions, conics and geometrical curves

BLOCK 2 Projection

- Unit 1: Orthographic Projection
- Unit 2: Projection of simple solids
- Unit 3: Section of Solids
- Unit 4: Half & Full Sectioning

BLOCK 3 Pictorial drawings

- Unit 1: Introduction
- Unit 2: Isometric Drawings
- Unit 3: Conversion of orthographic views

BLOCK 4 Development of Surfaces:

- Unit 1: Cube, Cylinder
- Unit 2: Prism
- Unit 3: Pyramids
- Unit 4: Tee and Elbow

BLOCK 5 AutoCAD

- Unit 1: Introduction
- Unit 2: AutoCAD commands
- Unit 3: Drawing -line, circle, arc, polygon,
- Unit 4: Drawing - ellipse, rectangle

Books :

1. Engineering Drawing by Gopalakrishnan.K.R., (Vol.I and Vol.II), Dhanalakshmi publishers, Edition 2, 1970
2. First Year Engineering Drawing by Barkinson & Sinha, Pitman Publishers, London, Edition 3, 1961
3. A Book on AutoCAD Release 2007.
4. Engineering Drawing by Shah/Rana,1st Edition Pearson Longman
5. Machine Drawing with AutoCAD by Pohit/Ghosh, 1st Edition Pearson Longman
6. Engineering Graphics by Prof.P.J.Shah, S.Chand & Co, New Delhi
7. Computer Graphics including CAD,AUTOCAD &C by A.M.Kuthe, S.Chand & Co, New Delhi

8. Engineering Graphics by Dhawan R.K, S.Chand & Co, New Delhi
9. Auto CAD 2005 for Engineers by Ionel Simon, Lakshmi Publications (Pvt) Ltd, New Delhi
10. Engineering Drawing by Agrawal, Tata McGraw Hill, New Delhi

Drawing Practices

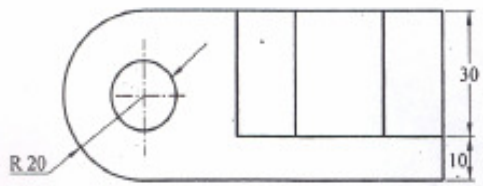

Fig - 1

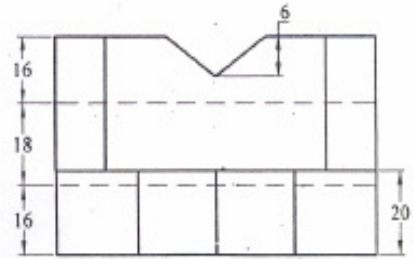

Fig- 2

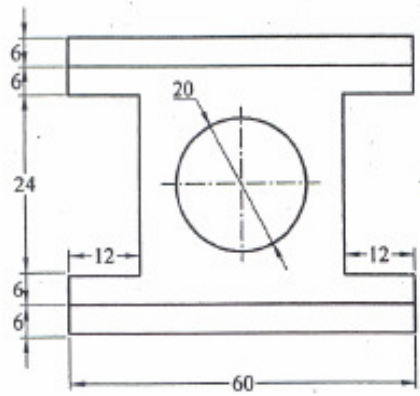

Fig. 3

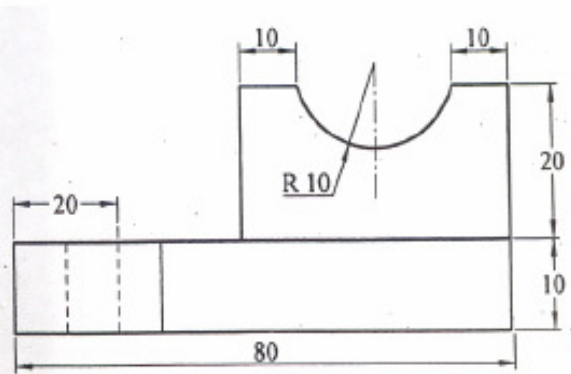

Fig. 4

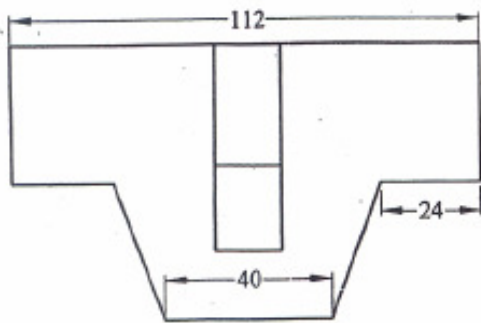

Fig. 5

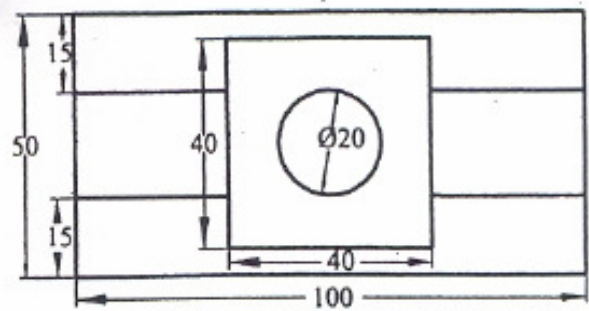

Fig. 6

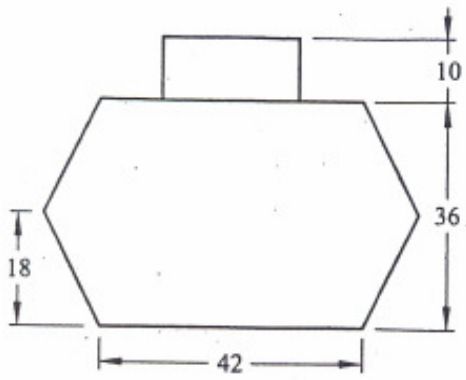

Fig. 7

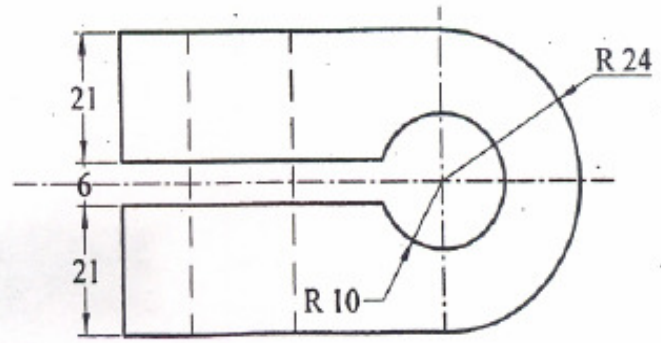

Fig. 8

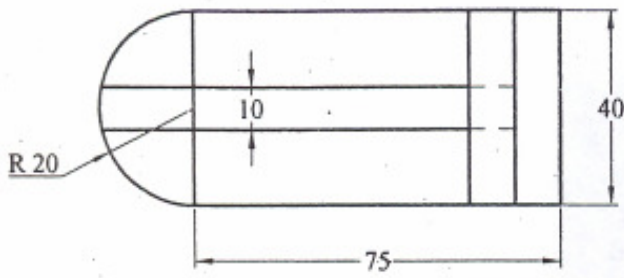

Fig. 9

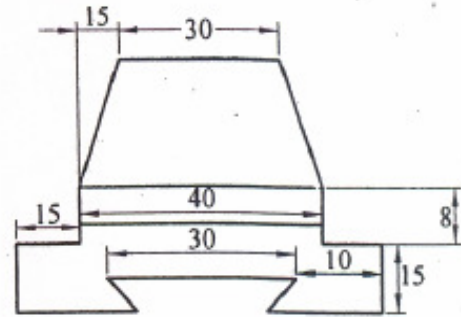

Fig. 10

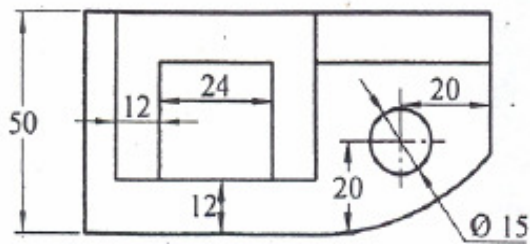

Fig. 11

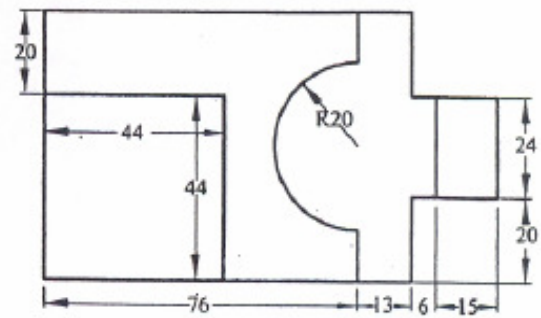

Fig. 12

SEMESTER : II

Subject Code : BE 205

Subject Title : Engineering Physics Lab

List of Experiments

1 VERNIER CALIPERS - To find the volumes of the solid cylinder and hollow cylinder using vernier callipers.

2 SCREW GAUGE – To find the thickness of (a) glass plate (b) given sphere using screw gauge. Hence calculate the volume of the glass plate and the sphere.

3 SIMPLE PENDULUM – To find the acceleration due to gravity in the laboratory, using simple pendulum. Calculate the acceleration due to gravity, by $L-T^2$ graph.

4 CONCURRENT FORCES -To verify the parallelogram law of forces and Lami's theorem.

5 COPLANAR – PARALLEL FORCES – To verify the conditions of the Co-planar parallel forces.

6 TORSION PENDULUM – To find the rigidity modulus of the thin wire and moment of inertia of the disc by using symmetric masses.

7 COMPARISON OF VISCOSITIES – To compare the coefficient of viscosities of two liquids by capillary flow method.

8 VISCOSITY OF A HIGHLY VISCOUS LIQUID – To find the coefficient of viscosity of a highly viscous liquid.

9 SURFACE TENSION: To find the surface tension of the given liquid by capillary rise method

10 YOUNG'S MODULUS – To find the young's modulus of the material of the given metre scale.

11 SPECTROMETER – 1. To find the angle of the prism.

12 SPECTROMETER – 2. To find the refractive index of the material of the prism.

13 DEFLECTION MAGNETOMETER – To compare the magnetic moments of two given magnets by (a) Equal distance method and (b) Null method.

14 SONO METER – To find the frequency of the given tuning fork.

15 JOULE'S CALORIMETER – To determine the specific heat capacity of the given liquid.

16 COPPER VOLTAMETER – To determine electro – chemical – equivalent of copper.

17 OHM'S LAW – To determine the resistance of two given coils of wire using Ohm's law. Also verify the laws of resistances.

18 POTENTIO METER – To compare the e.m.fs of two given cells.

19 PN JUNCTION DIODE – For the given semiconductor diode draw (a) Forward bias (b) Reverse bias characteristic curves.

20 SOLAR CELLS – V. I. Characteristics.

SEMESTER : II

Subject Code : BE 206

Subject Title : Applied Chemistry Lab

List of Experiments

1. Qualitative Analysis

Acid radicals : Chloride, Carbonate, Sulphate, Nitrate

Basic radicals: Lead, Cadmium, Copper, Aluminium, Zinc, Calcium, Magnesium, Ammonium

Identification of acid and basic radicals in

1. Lime Stone (Calcium Carbonate)
2. Pollutant (Lead nitrate or Cadmium Carbonate)
3. Fertilizer (Ammonium sulphate)
4. Electrolyte (Ammonium Chloride)
5. Fungicide (Copper sulphate)
6. Coagulant (Aluminium Sulphate)
7. Mordant (Zinc Sulphate)
8. Gypsum (Calcium Sulphate)
9. Epsom (Magnesium Sulphate)

10. Analysis of an Effluent (containing pollutants like Lead, Cadmium, Zinc, and Copper). Students may be given above four pollutants, in four separate test tubes in solution form and asked to report metallic pollutants with procedure (Basic Radical Analysis Procedure) and their harmful effects.

2. VOLUMETRIC ANALYSIS (DOUBLE TITRATIONS)

ACIDIMETRY AND ALKALIMETRY

1. Estimation of Hydrochloric acid
2. Estimation of Sodium Hydroxide
3. Estimation of Sodium Carbonate
4. Comparison of Strengths of two bases

PERMANGANIMETRY

5. Estimation of Ferrous Ammonium Sulphate
6. Estimation of Ferrous Sulphate
7. Comparison of Potassium Permanganate.

WATER ANALYSIS

8. Estimation of Total Hardness by EDTA method.
9. Calculation of pH of four sample solutions and calculation of H⁺ Ion concentration for a particular sample solution.

Subject Code : EE301
Subject Title : Circuit Theory

Structure of the Course Content

BLOCK 1 DC Circuits

- Unit 1: Electro Statics
- Unit 2: Basic Laws
- Unit 3: Series Circuits
- Unit 4: Parallel Circuits
- Unit 5: Problems in Series and Parallel Circuits

BLOCK 2 Network Theorems

- Unit 1: Node voltage Analysis
- Unit 2: Mesh Current Analysis
- Unit 3: Star Delta Transformations
- Unit 4: Thevenins and Norton Theorems
- Unit 5: Superposition and Maximum Power Transform Theorem

BLOCK 3 Single Phase AC Circuits

- Unit 1: Basic Definitions
- Unit 2: Resistor, Capacitor and Inductor in AC Circuits
- Unit 3: RL and RC Circuits
- Unit 4: Series RLC Circuits
- Unit 5: Parallel RLC Circuits

BLOCK 4 Three Phase AC Circuits

- Unit 1: Star Delta Connections
- Unit 2: Balanced Load and Unbalanced Load in Three Phase Circuits
- Unit 3: Measurements of Three Phase Power
- Unit 4: Effects of unbalanced Load
- Unit 5: Problems in Three Phase Circuits

BLOCK 5 DC Transients

- Unit 1: Basics of Transients
- Unit 2: Transients in RL
- Unit 3: Transients in RC
- Unit 4: Transients in RLC
- Unit 5: Problems

Books :

1. Electric Circuit Theory By Dr M. Arumugam, Dr N. Premkumar, Khanna Publishers
2. Electric Circuits By Joseph Edminister, Schaum Series
3. Circuits and Networks by A. Sudhakar, Shyam Mohan S Palli, Tata MC Publishers
4. Engineering Circuit Analysis by W H Hayt, J E Kemmerly, S M Durbin, TMC
5. Fundamental of Electric Circuits by Charles Alexandar, Matthew Sadiku, TMC
6. Electrical Networks by Ravish R Singh, Tata MC Publishers
7. Electric Circuits by N Nahvi, J A Edminister, K Uma Rao, Tata MC Publishers
8. Networks Analysis and Synthesis by S P Ghosh, A K Chakraborty, Tata MC
9. Electric Circuit Analysis by T V Narmadha, Lakshmi Publications Pvt Ltd, New Delhi
10. Electrical and Electronics Engineering by Vikramadithya Dave, Lakshmi Publications Pvt Ltd, New Delhi

Subject Code : EE302
Subject Title : Electronic Devices

Structure of the Course Content

BLOCK 1 Component and Diodes

- Unit 1: Resistor
- Unit 2: Diode
- Unit 3: Rectifiers
- Unit 4: Filters

BLOCK 2 Bipolar Junction Transistors

- Unit 1: Transistor Biasing
- Unit 2: Transistor Configuration
- Unit 3: RC Coupled Amplifier
- Unit 4: Feedback Amplifiers

BLOCK 3 Transistor Oscillators and FET, UJT

- Unit 1: Oscillator
- Unit 2: FET
- Unit 3: FET Amplifiers and choppers
- Unit 4: UJT

BLOCK 4 Thyristors

- Unit 1: SCR
- Unit 2: DIAC
- Unit 3: TRIAC
- Unit 4: MOSFET and IGBT

BLOCK 5 Opto Electronic Devices and Wave shaping Circuits

- Unit 1: LDR, LED and LCD
- Unit 2: Opto Coupler, Interrupter
- Unit 3: Clipping and Clamping Circuits
- Unit 4: Multivibrators

Books :

1. Principle of Electronics By VK Metha
2. Electronic Principles by Malvino, Tata MC Publishers
3. Electronics Devices and Circuits by Allen Mottershed, Tata McGraw – Hill Publication
4. Electronics Devices and Circuits by Jacob Millman and Halkies, Tata McGraw – Hill Publication
5. Optical Fiber Communication by Gerd Keiser
6. Electronics Devices and Circuits by Sachin S Saharma by Lakshmi Publications Pvt Ltd, New Delhi
7. Electronics Devices and Circuits by Balwinder Singh, Ashish Dixit, Balwant Raj by Lakshmi Publications Pvt Ltd, New Delhi
8. Analog and Digital Electronics by Bhupesh Bhtia, Sunil Paliwal, Balvir Singh, Navneet Sharma, Lakshmi Publications Pvt Ltd, New Delhi
9. Basic Electronics by Rakesh Kumar Garg, Asish Dixit, Pawan Yadav, Lakshmi Publications Pvt Ltd, New Delhi
10. Basic Electronics Engineering & Devices by Dr.R.K.Singh, Asish Dixit, Lakshmi Publications Pvt Ltd, New Delhi

Subject Code : EE303
Subject Title : Electrical Machines -I

Structure of the Course Content

BLOCK 1 Electromagnetism

- Unit 1: Basic Laws
- Unit 2: Storage Elements
- Unit 3: Self Inductance
- Unit 4: Mutual Inductance

BLOCK 2 Transformers

- Unit 1: Principle of working
- Unit 2: Phase Diagram
- Unit 3: Losses and Efficiency
- Unit 4: Three Phase Transformer

BLOCK 3 DC Generators

- Unit 1: Principle of working
- Unit 2: Load Characteristics
- Unit 3: Losses and Efficiency
- Unit 4: Applications of DC Generators

BLOCK 4 DC Motor

- Unit 1: Principle of working
- Unit 2: Load Characteristics
- Unit 3: Losses and Efficiency
- Unit 4: Speed Control and Applications of DC Motors

BLOCK 5 Maintenance of Machines

- Unit 1: Sparking
- Unit 2: Growler
- Unit 3: Protective Devices
- Unit 4: Fundamental Rules for Maintenance

Books :

- 1.A Course in Electrical Engg (Vol II) By BL Theraja, S.Chnad Publishers
- 2.Electrical Technology By JB Gupta, S.K. Kataria & Sons
- 3.Electrical Technology by Edward Hughes, English Language Book Society, Longman, England
- 4.Operation & Maintenance Electrical Equipment by B.V.S. Rao, Media Promoters & Publishers Pvt. Ltd., Bombay
- 5.Electrical Machines by Bhattacharya, Tata McGraw Hill Co, New Delhi
6. Electrical Energy Systems Theory by Elegerd, Tata McGraw Hill Co, New Delhi
- 7.Electric Machinery by Fitzgerald, Tata McGraw Hill Co, New Delhi
8. Electrical Machines(Sigma Series) by Kothari, Tata McGraw Hill Co, New Delhi
- 9.Electrical Machines by Kothari & Nagarth, Tata McGraw Hill Co, New Delhi
- 10.Direct Current Machines by R.K.Rajput, Lakshmi Publications Pvt Ltd, New Delhi

Subject Code : EE 304
Subject Title : Engineering Mechanics

Structure of the Course Content

BLOCK 1 Mechanical Properties of Materials

- Unit 1: Basic Definitions
- Unit 2: Stress
- Unit 3: Strain
- Unit 4: Stress-Strain Calculations

BLOCK 2 Geometrical Properties of Sections

- Unit 1: Basic Definitions
- Unit 2: Moment of Inertia
- Unit 3: Thin cylinders
- Unit 4: Thin Spherical Shells

BLOCK 3 Theory of Simple Bending

- Unit 1: Shear Force
- Unit 2: Bending Moment
- Unit 3: Cantilever
- Unit 4: Simple Bending

BLOCK 4 Torsion and Springs

- Unit 1: Theory of Torsion
- Unit 2: Torsional Rigidity
- Unit 3: Hollow Shaft
- Unit 4: Springs

BLOCK 5 Deflection

- Unit 1: Beams
- Unit 2: Friction
- Unit 3: Gear Drives
- Unit 4: Belt Drives

Books :

1. Applied Mechanics by A.K.Upadhyay, Charotar Publishers
2. Strength of Materials by R.S.Khurmi, S.Chand & Co
3. Applied Mechanics by SB Junnarkar, Dr. HJ Shara, Charator publishing house, Anand 388001
4. Strength of Materials by S. Ramamrutham Dhanpat Rai Pub. Co, New Delhi.
5. Strength of Materials by L.Negi, Tata McGraw Hill, New Delhi
6. Schaum's Outline Of Statics and Mechanics of Materials by William Nash, Tata McGraw Hill, New Delhi
7. Mechanics of Materials by Ferdinand Beer.E, Russell Johnson, Jr John DeWolf.David Mazurek, Tata McGraw Hill, New Delhi
8. Strength of Materials by S.Rattan, Tata McGraw Hill, New Delhi
9. Strength of Materials by B.Sarkar, Tata McGraw Hill, New Delhi
10. Mechanics of Materials by Ansel Ugural, Tata McGraw Hill, New Delhi

Subject Code : EE305

Subject Title : Electronic Devices Lab

Structure of the Course Content

1. VI Characteristics of PN JN Diode
2. VI Characteristics of Zener diode.
3. HW, FW with and without filter.
4. Bridge Rectifier with and without filters.
5. VI characteristics of Regulator.
6. Input/output characteristics of CE Transistor.
7. Frequency response of RC coupled amplifier.
8. Emitter follower.
9. Negative feedback amplifier.
10. RC phase shift oscillator.
11. Hartley and Colpitts oscillator.
12. JFET characteristics.
13. Common source amplifier.
14. UJT characteristics.
15. UJT relaxation oscillator.
16. SCR characteristics.
17. DIAC and TRIAC characteristics.
18. Clipper, clamper and voltage doubler.
19. LDR, Photo diode and Photo transistor characteristics.
20. Solar cell and opto coupler.

Subject Code : EE306

Subject Title : Electrical Machines –I Lab

Structure of the Course Content

1. No load and load characteristics of self excited DC shunt generator
2. Load characteristics of self excited DC series generator
3. Load test on a DC shunt motor
4. Load test on a DC series motor
5. Load test on a DC compound motor
6. Predetermine the efficiency of a DC machine by Swinburne's test
7. Equivalent circuit of a single phase transformer by conducting open circuit and short circuit test.
8. Predetermination of the efficiency and regulation of a single phase transformer
9. Load test on a single phase transformer
10. Load test on a three phase transformer
11. Parallel operation of two similar single phase transformers

Subject Code : EE401
Subject Title : Linear and Digital ICs

Structure of the Course Content

BLOCK 1 Linear IC

- Unit 1: OP Amp
- Unit 2: Timer Circuits
- Unit 3: Multivibrators
- Unit 4: Voltage Regulators

BLOCK 2 Boolean algebra

- Unit 1: Number Systems
- Unit 2: Basic Laws and Theorems
- Unit 3: Basic Logic Gates
- Unit 4: Karnaugh Maps

BLOCK 3 Combinational logic

- Unit 1: Arithmetic Circuits
- Unit 2: Adders
- Unit 3: Encoders and Decoders
- Unit 4: IC Families (TTL, CMOS, LS)

BLOCK 4 Sequential logic

- Unit 1: Flip Flops
- Unit 2: Counters
- Unit 3: State Diagram
- Unit 4: Shift Registers

BLOCK 5 D/A, A/D and Memory

- Unit 1: D/A Converter
- Unit 2: R-2R ladder Network
- Unit 3: A/D Converters
- Unit 4: Memories

Books :

1. Modern Digital Electronics By RP Jain, TataMcHill Publishers
2. Digital Principles and Applications By AP Malvino and Leach TataMcHill Publishers
3. Digital Electronics by Roger L. Tokheim Macmillan, TataMcHill Publishers
4. Digital Electronics – An introduction to theory and practice by William H. Gothmann, PHI
5. Electronic devices, Applications and Integrated Circuits by Satnam P. Mathur and others, Umesh Publications
6. Linear Integrated Circuits by Salivahanan, Tata McGraw Hill, New Delhi
7. Linear Integrated Circuits(Sigma) by Bali, Tata McGraw Hill, New Delhi
8. Design with Operational Amplifiers & Analog Integrated Circuits by Franco, Tata McGraw Hill, New Delhi
9. Design of Analog CMOS Integrated Circuits by Razavi, Tata McGraw Hill, New Delhi
10. Analog and Digital Electronics by Bhupesh Bhatia, Sunil Paliwal, Balvir Singh, Navneet Sharma, Lakshmi Publications Pvt Ltd, New Delhi

Subject Code : EE402

Subject Title : Computer Hardware and Networking

Structure of the Course Content

BLOCK 1 Mainboards and Processors

Unit 1: Introduction to Computers

Unit 2: Mainboard and Chipsets

Unit 3: Interface Bus Standards

Unit 4: Processors

BLOCK 2 Peripherals

Unit 1: Input Devices

Unit 2: Output Devices

Unit 3: Storage Devices (HDD)

Unit 4: Removable Storage Devices (CD/DVD, FDD)

BLOCK 3 I/O Ports and External Peripherals

Unit 1: Video Capture and Sound Card

Unit 2: Serial and Parallel Ports and Power Supply Unit

Unit 3: Modem, Digital Cameras

Unit 4: Printer and Scanners

BLOCK 4 PC assembling and testing

Unit 1: PC assembly

Unit 2: CMOS Setup

Unit 3: POST

Unit 4: Diagnostic Software and Anti Virus

BLOCK 5 Computer Network and Installation

Unit 1: Network Basics

Unit 2: LAN

Unit 3: Media and Hardware

Unit 4: Network Administration

Books :

1. IBM PC and CLONES by B.Govindrajalu, Tata McGraw-Hill Publishers
2. Computer Installation and Servicing by D.Balasubramanian, Tata McGraw Hill , 2005
3. Computer Installation and Troubleshooting by M.Radhakrishnan, ISTE- Learning Materials 2001
4. The complete PC upgrade and Maintenance by Mark Minasi, BPB Publication
5. Inside the PC by Peter Norton, Tech Media
6. Troubleshooting, Maintaining and Repairing PCs by Stephen J Bigelow, Tata MCGraw Hill Pub 2001
7. Basic Refrigeration and Air-Conditioning by Ananthanayanan P.N, Tata McGraw-Hill
8. PC hardware by Balvir Singh, Lakshmi Publications (Pvt) Ltd, New Delhi
9. PC Repair and Maintenance: A Practical Guide by Joel Rosenthal, Kevin Irvin, Lakshmi Publications (Pvt) Ltd, New Delhi
10. PC Architecture and Peripherals-I by Dinesh Maldasani, Lakshmi Publications (Pvt) Ltd, New Delhi

Subject Code : EE403

Subject Title : Measurements and Instruments

Structure of the Course Content

BLOCK 1 Classifications of Instruments

Unit 1: Basic Definitions

Unit 2: Indicating Instruments

Unit 3: Integrating Instruments

Unit 4: Control Mechanism of Instruments

BLOCK 2 Measurements of Electrical Quantities

Unit 1: Construction and working Principles of meters

Unit 2: Induction type meters

Unit 3: Earth Testers

Unit 4: CRO

BLOCK 3 Measurement of Power and energy

Unit 1: Types of Watt Meters

Unit 2: 2 Watt Meter Method

Unit 3: Energy Meter

Unit 4: Calibration of meters

BLOCK 4 Special Instruments

Unit 1: MD Indicator

Unit 2: Synchroscope

Unit 3: Frequency Meter

Unit 4: Recorders

BLOCK 5 Transducers

Unit 1: Electrical Transducers

Unit 2: LVDT

Unit 3: Piezo Electric sensors

Unit 4: Proximity sensors

Books :

1. A course in Electrical and Electronics Measurements and Instrumentation by A.K. Sawhney, Dhanpat Rai Publishers
2. Electronic Instrumentation by H.S. Kalsi, TataMcHill Publishers
3. Modern Electronic Instrumentation and Measurement techniques by Albert D. Helfrick William David Cooper, Prentice-Hall of India (P) Ltd., New Delhi
4. Electronics and Instrumentation by Dr.S.K.Battachariya, Dr.Renu Vig, S.K.Kataria & Sons, New Delhi
5. A course in electrical and electronic measurements and instrumentation by Umesh Sinha, Satya Prakashan, New Delhi
6. Digital Instrumentation by Bouwens, Tata McGraw Hill, New Delhi
7. Electronic Measurements and Instrumentations by Oliver, Tata McGraw Hill, New Delhi
8. Instrumentation: Devices and Systems by Rangan, Tata McGraw Hill, New Delhi
9. Basic Electronics and Instrumentations by Saifullah Khalid, Neetu Agarwal, Mukesh Jain, Lakshmi Publications (Pvt) Ltd, New Delhi
10. Hand Book of Analytical Instruments by Khandpur R S, Tata McGraw Hill, New Delhi

Subject Code : EE404
Subject Title : Electrical Machines - II

Structure of the Course Content

BLOCK 1 Alternators

- Unit 1: Basic Principle and Working of Alternators
- Unit 2: Types of Alternator
- Unit 3: EMF Equation
- Unit 4: Performance of Alternators

BLOCK 2 Synchronous motor

- Unit 1: Working Principle
- Unit 2: Vector Diagram
- Unit 3: Effect of Change in Excitation
- Unit 4: Power factor improvement

BLOCK 3 Three phase induction motor

- Unit 1: Principle of Operation
- Unit 2: Slip-Torque Characteristics
- Unit 3: Circle Diagram
- Unit 4: Speed Control

BLOCK 4 Single phase motor

- Unit 1: Construction and Principle of Operation
- Unit 2: Split Phase Motor
- Unit 3: Shaded Pole Motor
- Unit 4: Universal Motor

BLOCK 5 Maintenance of inductance motor

- Unit 1: BIS Code of Practice
- Unit 2: Rating
- Unit 3: Selection of Induction Motors
- Unit 4: Starters

Books :

1. Electrical Machines by SK Bhattacharya, TataMcHill Publishers
2. A Text Book Electrical Technology by BL Theraja, S.Chand Publishers
3. Operation and Maintenance of Electrical Machines by B.V.S. Rao, Khanna Publishers, New Delhi.
4. Electrical Technology by Edward Hughes, Addison – Wesley International Student Edition
5. Performance & Design of AC Machines by MG Say, CBS Publication, New Delhi
6. Electrical Energy Systems Theory by Egeerd, Tata McGraw Hill Co, New Delhi
7. Electric Machinery by Fitzgerald, Tata McGraw Hill Co, New Delhi
8. Electrical Machines(Sigma Series) by Kothari, Tata McGraw Hill Co, New Delhi
9. Electrical Machines by Kothari & Nagarth, Tata McGraw Hill Co, New Delhi
10. Electrical and Electronics Engineering by Vikramaditya Dave, Lakshmi Publications (Pvt) Ltd, New Delhi

Subject Code : EE405

Subject Title : IC Lab

LIST EXPERIMENTS

1. Construct and test a) Inverting Amplifier and b) Non inverting amplifier using Op- -- Amp.
2. Construct and test a) Scale changer circuit b) Summer circuit using Op.Amp.
3. Construct and test a) Differentiator circuit b) Integrator circuit using Op. Amp.
4. Construct and test a) Astable Multivibrator using IC 555 and test its performance.
5. Construct and test a) Monostable Multivibrator using IC 555 and test its performance.
6. Verify the truth table for the following gates AND, OR, NOT, NAND, NOR, EX-OR USING 74XX Ics.
7. Construct other gates using NAND gates.
8. Construct a Half Adder using 7408, 7432, 7486, Ics and verify its truth table.
9. Construct Full Adder and verify the truth table using 74XX Ics.
10. Construct Half Subtractor and verify its truth table using 74XX Ics.
11. Construct Full Subtractor and verify its truth table using 74XX Ics.
12. Construct and verify the truth table of RS,D and JKM FFS.
13. Construct a 4 bit BCD counter using 7473 Ics and observe the output waveform.
14. Construct a Decade counter using 7473 Ics and observe the output waveform.
15. Construct and verify the performance of a 1 digit counter using 7490, 7447, 7475 and seven segment LEDs.
16. Construct a 4 bit weighted Resistor D/A converter and test its performance.
17. Construct a 4 bit r-2R Ladder D/A converter and test its performance.
18. Verify the operation of ADC.

Subject Code : EE406
Subject Title : Electrical Machines – II Lab
Structure of the Course Content

1. Predetermination of regulation of alternator by synchronous impedance method.
2. Load Test on single Phase alternator.
3. Load Test on three Phase Alternator.
4. Synchronising of two alternators by lamp & synchroscope method.
5. Determination of 'V' Curve and inverted 'V' curves of a three phase synchronous motor.
6. Conduct load test on a single phase induction motor and plot
 - a. Load Vs efficiency
 - b. Load Vs Power factor
 - c. Torque Vs Slip characteristic curves.
7. Conduct load test on three phase induction motor and plot
 - a. Load Vs Efficiency
 - b. Load Vs P.f.
 - c. Torque Vs Slip characteristic curves.
8. Conduct load test on 3 phase slipring Induction motor and plot
 - a) Output Vs efficiency
 - b) Output Vs Torque
 - c) Output Vs slip Characteristics.
 - d) Output Vs Line Current
 - e) Output Vs P.F
9. Draw the equivalent circuit of a 3 phase Induction motor by conducting No load and Blocked rotor test.
10. Draw the circle diagram for 3 phases Induction Motor by conducting suitable Tests.

Subject Code : EE501
Subject Title : Power Systems I

Structure of the Course Content

BLOCK 1 Generation and Conservation of Electrical Power

- Unit 1: Conventional methods of power generations
- Unit 2: Economics of power factor improvement
- Unit 3: Introduction to energy conservation
- Unit 4: Principles of energy audit and Energy Management

BLOCK 2 Transmission (AC and Heavy DC)

- Unit 1: Typical lay out of AC power supply scheme
- Unit 2: Over Head lines
- Unit 3: Effect of load and power factor on regulation and efficiency
- Unit 4: High voltage DC transmission

BLOCK 3 Insulators (OH Line and UG Cable Lines)

- Unit 1: Types of line insulators
- Unit 2: Corona
- Unit 3: Various parts of a three conductor UG cable
- Unit 4: Cable Faults

BLOCK 4 Protective Elements

- Unit 1: Circuit Breakers
- Unit 2: Classification of Circuit Breakers
- Unit 3: DC breaking
- Unit 4: Fuses

BLOCK 5 Relays and Earthing

- Unit 1: Protective relay
- Unit 2: Functional relay types
- Unit 3: Static relay
- Unit 4: Grounding

Books :

1. Principles of Power Systems by VK Metha, S.Chand Publishers
2. Electrical Power System Planning by AS Pabla, McMillan Publishers
3. Electrical Power System by CL. Wadhawa, New Age International
4. A Course in Electrical Power by Soni, Gupta Bhatnagar, Dhanpath Rai & Co (P)Ltd., New Delhi
5. Electrical Power by S.L. Uppal, Khanna Publishers, New Delhi
6. A Course in Electrical Power by J.B. Gupta, Katson Publishing House,
7. HVDC Power Transmission System & Technology by KR. Padiyar, New Age International New Delhi
8. Digital Protection –Protective relaying from electromechanical to microprocessor by L.P.Singh, New Age International New Delhi
9. Power system Protection and Switch gear by B.Ram D.N.Viswakarma, TMH
10. Power System Protection and Switchgear by B.Ravindranath M.Chadar, New Age International

Subject Code : EE502

Subject Title : Microprocessors and Microcontrollers

Structure of the Course Content

BLOCK 1 8085MPU and Applications

Unit 1: Evolution of Microprocessors and 8085 Architecture

Unit 2: Instruction format & set and Addressing Modes

Unit 3: Simple Programs and Branching Instructions

Unit 4: Interrupt Structure, Memory mapping and Status signals

BLOCK 2 8051 Microcontroller

Unit 1: Architecture and Pin Configurations

Unit 2: Timing and Clock

Unit 3: Flags and Registers and SFR(s)

Unit 4: Interrupts (External and Internal)

BLOCK 3 Programming Concepts

Unit 1: Tool chain and Techniques

Unit 2: Addressing Modes and Instructions

Unit 3: Programs (Add, Sub Multiplication and Div)

Unit 4: Programs (Sum, ascending, Descending, Largest and smallest of N numbers)

BLOCK 4 Programming Concepts

Unit 1: Block and Signal Diagrams

Unit 2: Control word format

Unit 3: Peripheral Devices (8255, 8254, 8259, 8279)

Unit 4: Serial and AD/DAC Interfacing

BLOCK 5 Applications

Unit 1: I/O Interface (Keyboard and LCD)

Unit 2: Traffic Light Controller

Unit 3: Temp Controller, Freq and Period Measurement

Unit 4: Motor, Solenoids relay Interfaces.

Books :

1. Microprocessor and Microcontroller by R.Theagarajan, Sci tech Publications
2. The 8051 Microcontroller By Kenneth J Ayala, Penram Internationala Publication
3. 8085 Microprocessor and its applications by Ramesh gaonkar, Penram Publishers
4. 8086 Microprocessor by Douglas hall
5. www.Intel.com
6. Microprocessors and Interfacing by Douglas V.Hall and Hepper,K.M, Tata McGraw-Hill
7. Advanced Microprocessors & Peripherals by Dr. Ajoy Kumar Ray and K.M.Burchandi, Tata McGraw-Hill
8. Advanced Microprocessors and Interfacing by Badri Ram, Tata McGraw-Hill
9. Introduction to Microprocessors by A.P.Mathur, Tata McGraw-Hill
10. Microprocessor 8085 by G.T.Swamy, Lakshmi Publications (Pvt) Ltd, New Delhi
10. Advanced Microprocessor and Microcontrollers by Prof S.K.Venkata Ram, Lakshmi Publications (Pvt) Ltd, New Delhi

Subject Code : EE503
Subject Title : Electrical Machine Design

Structure of the Course Content

BLOCK 1 Fundamental Principles

Unit 1: Standards and Specifications of DC and AC machines

Unit 2: Design and Constructions

Unit 3: Materials used

Unit 4: Losses (Elect, Magnetic & Temp)

BLOCK 2 Magnetic Circuit Calculations

Unit 1: Force Calculations

Unit 2: Force (in teeth, gap)

Unit 3: Flux and Reactance

Unit 4: Rotating machines

BLOCK 3 Transformer Design

Unit 1: Core and Shell Types

Unit 2: Generation and Distribution transformer

Unit 3: Single and Multi Phase

Unit 4: Electric Loading and Winding design

BLOCK 4 DC machines Design

Unit 1: Poles

Unit 2: Commutator and Thyristor supply

Unit 3: Electric Loading

Unit 4: Flowchart estimation for KW and Dimension

BLOCK 5 AC Machines Design

Unit 1: Design Considerations and Power equations

Unit 2: Three Phase Motor design

Unit 3: Synchronous Motor

Unit 4: Rotor design

Books :

1. Principles of electrical Machine Design, by SK Sen. Oxford & IBH Publishers
2. The performance and design of AC machines by MG Say, CBS publishers
3. Elements of Electrical machine design by Alfred still, Charles S.siskind, McGraw – Hill, New Delhi

Subject Code : EE504

Subject Title : Control of Electrical Machines

Structure of the Course Content

BLOCK 1 Control Circuit Components

Unit 1: Switches

Unit 2: Relays

Unit 3: Solenoid

Unit 4: Timers

BLOCK 2 DC Motor Controls

Unit 1: Current limiters, Starters

Unit 2: Acceleration & EMF Starters

Unit 3: Jogging, Braking, Reversing Control

Unit 4: UJT & SCR Speed Controls

BLOCK 3 AC Motor Control Circuits

Unit 1: Motor Current and Starters

Unit 2: DOL and Auto Transformer Starters

Unit 3: Star/Delta Starter, Dynamic Braking

Unit 4: Secondary Frequency Acceleration Starters

BLOCK 4 PLCs

Unit 1: Introduction and Advantages

Unit 2: PLC Operation and Programming

Unit 3: Ladder logic Diagram

Unit 4: PLC instructions and I/O Module & Scan

BLOCK 5 Transformer Maintenance

Unit 1: Inspection and Installation

Unit 2: OIL Testing and Purification

Unit 3: Dismantling and Circuit test

Unit 4: Protection and Earthling

Books :

1. Control of Electrical Machines by SK Bhattacharys, New Age International Publishers
2. Operation and Maintenance of Electrical machines by BVS Rao, Khanna Publishers
3. Automation, Production System And Computer-Integrated Manufacturing by Mikell P. Groover, Prentice Hall of India (P) Ltd., New Delhi
4. Direct Current Machines by R.K.Rajput, Lakshmi Publications (Pvt) Ltd, New Delhi
5. Alternating Current Machines by R.K.Rajput, Lakshmi Publications (Pvt) Ltd, New Delhi
6. Principles of Power Systems by VK Metha, S.Chand Publishers
7. Electrical Power System Planning by AS Pabla, McMilan Publishers
8. Electrical Power System by CL. Wadhawa, New Age International
9. Introduction to Programmable Logic Controllers by Gary Dunning, Thomson Delmar Learning Second Edition

Subject Code : EE505

Subject Title : Control of Electrical Machines Lab

Structure of the Course Content

1. Perform breakdown test and determine the dielectric strength of transformer oil
2. Conduct acidity test on transformer oil
3. Test the timing characteristic of thermal overload relay
4. Wire and test the control circuit for jogging in cage motor
5. Wire and test the control circuit for semi-automatic star-delta starter
6. Wire and test the control circuit for automatic star-delta starter
7. Wire and test the control circuit for dynamic braking of cage motor
8. Wire and test the control circuit for two speed pole changing motor
9. Wire and test the control circuit for automatic Rotor resistance starter
10. Conduct test on speed control of DC motor using SCR
11. Test the working of single phase preventer
12. Wire and test the DOL starter using PLC
13. Wire and test the Star-Delta starter using PLC
14. Wire and test the control circuit for jogging, forward and reverse operations using PLC
15. Wire and test the single phase preventer using PLC
16. Testing of 25 KVA, 11 KV/400 V distribution transformer – voltage test
Continuity test and short circuit test
17. Dismantling and re-assembling of 25 KVA, 11KV/400 V distribution transformer

Subject Code : EE506

Subject Title : Microcontroller Lab

Structure of the Course Content

1. Introduction of Microcontroller Kit
2. Addition, Subtraction
3. Multi-byte addition
4. Multiplication of two numbers
5. Finding the maximum value in an array
6. Arranging the given data in ascending order
7. BCD to Hex conversion
8. Hex to BCD conversion
9. Hex to ASCII
10. ASCII to Binary
11. Square Root of a given data
12. Least Common Multiple
13. Greatest Common Divisor
14. Parity bit generation
15. Program using I/Os in port 1
16. Counter using timer
17. Program using interrupt
18. Digital I/O
19. Matrix keyboard
20. Seven segment displays
21. LCD Displays
22. Traffic light
23. 8 bit ADC and 8 bit DAC
24. STEPPER MOTOR CONTROL
25. DC motor control
26. Lift control
27. Sending data through serial port between controller kits

Subject Code : EE601
Subject Title : Power Systems II

Structure of the Course Content

BLOCK 1 Distribution

- Unit 1: Classification of Distribution Systems
- Unit 2: Types of AC distributions
- Unit 3: Sub Stations
- Unit 4: Bus-Bar Systems

BLOCK 2 Industrial Drives

- Unit 1: Introduction
- Unit 2: Types of Drives
- Unit 3: Performance Characteristics of Motor
- Unit 4: Selection and Applications

BLOCK 3 Electrical Traction

- Unit 1: Traction Systems
- Unit 2: Track Electrification System
- Unit 3: Traction Mechanics
- Unit 4: Traction Motors

BLOCK 4 Traction Control

- Unit 1: Principle of DC Traction Control
- Unit 2: Various Methods of DC Traction
- Unit 3: Thyristor Control & Bracking Systems
- Unit 4: Illumination Methods

BLOCK 5 Electric Heating and Welding

- Unit 1: Electric Heating
- Unit 2: Resistance ovens and Furnaces
- Unit 3: Induction Furnaces
- Unit 4: Welding

Books:

1. A Course in Electrical Power by JB Gupths, Katson Publishing Co.
2. Electric Power by S. Uppal, Khanna Publishers.
3. Principles of Power Systems by VK Metha, S.Chand Publishers
4. Electrical Power System Planning by AS Pabla, McMilan Publishers
5. Electrical Power System by CL. Wadhawa, New Age International
6. A Course in Electrical Power by Soni, Gupta Bhatnagar, Dhanpath Rai & Co (P)Ltd., New Delhi
7. HVDC Power Transmission System & Technology by KR. Padiyar, New Age International New Delhi
8. Digital Protection –Protective relaying from electromechanical to microprocessor by L.P.Singh, New Age International New Delhi
9. Power system Protection and Switch gear by B.Ram D.N.Viswakarma, TMH
- 10.Power System Protection and Switchgear by B.Ravindranath M.Chadar, New Age International

Subject Code : EE602
Subject Title : Power Electronics

Structure of the Course Content

BLOCK 1 Thyristor Family Trigger and Commutation Circuits

- Unit 1: SCR Working & Characteristics
- Unit 2: IGBT & MOSFET Working & Characteristics
- Unit 3: DIAC, TRIAC, SCRS, SUS LASCRC & GTO Study
- Unit 4: Trigger and Commutation Circuits

BLOCK 2 Phase Controlled Rectifier

- Unit 1: Classification Of rectifier and Characteristics
- Unit 2: Waveform and Power Factors for Various Rectifiers
- Unit 3: Three Phase Full and Half Wave Rectifiers
- Unit 4: Protection Converter

BLOCK 3 Choppers and Inverters

- Unit 1: Choppers and it's working
- Unit 2: Types of Chopper
- Unit 3: Inverters and it's working
- Unit 4: Applications of Choppers and inverters

BLOCK 4 Control of DC Drives

- Unit 1: DC Motor Speed Equation and Current Control
- Unit 2: Schemes of Excitations
- Unit 3: DC-DC Converters using MOSFET, IGBT
- Unit 4: Closed Loop Control

BLOCK 5 AC Drives

- Unit 1: Torque and Speed Characterstics of 3 Phase motor
- Unit 2: Closed loop control
- Unit 3: Cycloconverter
- Unit 4: Cycloconverter working

Books :

1. Power Electronics by MD Singh & KB Khanchandaniata Tata MC Hill
2. Fundamentals of Electrical Drives by GK Dubey, Narosa Publishing
3. Power Electronics-Converter Applications and Design by Mohan Underland Robbins, John Wiley and Sons ,NewYork
4. Fundamentals of Power Electronics by S.RamaReddy, NarosaublishingHouse,New Delhi
5. Power Electronics by Dr P.S.Bimhra, Khanna Publishers
6. Power Electronics by P C Sen, Tata McGraw Hill Publishing Company New Delhi,
7. Power Electronics by MUHAMMED H.RASHID, Prentice-Hall of India Pvt.Ltd New Delhi
8. Power Electronics by Singh, TMC
9. Power Electronics: Principle and Application by Vithayathil, TMC

Subject Code : EE603
Subject Title : Electrical Estimation
Structure of the Course Content

BLOCK 1 Electrical Symbols

- Unit 1: Main and Distribution fuse-board with switches
- Unit 2: Junction of conductors
- Unit 3: UG,OH Lines Proposed and Existing, Motors etc
- Unit 4: Sockets, Fuses, Rewireable Fuses and Consumer Appliances (Viz Fan Heater)

BLOCK 2 Indian Electricity Rules

- Unit 1: Rule 28, 30,31
- Unit 2: Rule 46,47,54
- Unit 3: Rule 56,77,79
- Unit 4: Rule 87,88

BLOCK 3 Specifications of Electrical Items

- Unit 1: Switches & Sockets and Switch Boards & Boxes
- Unit 2: Circuit Breaker and Regulators
- Unit 3: Heaters and UG Cables & Wires
- Unit 4: Lamps, Meters, Motors, Alternators

BLOCK 4 Wiring

- Unit 1: Internal Wiring
- Unit 2: Types and procedures of wiring
- Unit 3: Earthing
- Unit 4: Testing and Installation

BLOCK 5 Domestic, Commercial and Industrial Installation

- Unit 1: Conditions and Requirements
- Unit 2: Steps in electrical estimate
- Unit 3: Estimate the quantity of material required for various types buildings
- Unit 4: Street Light

Books :

1. Electrical Wiring, Estimating and Costing By Dr.S.L.Uppal, Khanna Publishers.
2. Electrical Design Estimating and Costing By K.B.Raina & S.K.Battacharya. New age international Publishers
3. Basic Electrical Engineering by M.L.Anwani, Dhanpat Rai & Sons, New Delhi

Subject Code : EE604

Subject Title : Power Electronics Lab

Structure of the Course Content

1. Get the knowledge about the trigger circuit
2. Draw the input/output waveform using HCB and FCB
3. Know the performance of lamp control using DIAC-TRIAC
4. Learn the various techniques used for turn-off of Thyristor
5. Draw the waveform of series/parallel inverter
6. Draw the output waveform of DC chopper
7. Measure the output voltage of chopper
8. Find the performance of speed control of universal motor
9. Understand the concept of Closed loop control of AC motor
10. Know the performance of speed control of DC motor by varying firing angle
11. Understand the concept of Closed loop control of DC motor
12. Draw the output waveform of DC chopper using MOSFET/IGBT
13. Measure the variable output voltage using PWM technique

Subject Code : **EE605**
Subject Title : **Project work**